

Features

- ✧ For surface mounted application
- ✧ Glass passivated junction chip
- ✧ Built-in strain relief, ideal for automated placement
- ✧ Plastic material used carries Underwriters Laboratory Classification 94V-0
- ✧ Fast switching for high efficiency
- ✧ High temperature soldering: 260°C / 10 seconds at terminals
- ✧ Green compound with suffix "G" on packing code & prefix "G" on datecode



Mechanical Data

- ✧ Case: Molded plastic
- ✧ Terminals: Pure tin plated, Lead free
- ✧ Polarity: Indicated by cathode band
- ✧ Packing: 16mm tape per EIA STD RS-481
- ✧ Weight: 0.21 grams

Ordering Information (example)

Part No.	Package	Packing	Packing code	Packing code (Green)
RS3A	SMC	850 / 7" REEL	R7	R7G

Maximum Ratings and Electrical Characteristics

Rating at 25 °C ambient temperature unless otherwise specified.

Parameter	Symbol	RS 3A	RS 3B	RS 3D	RS 3G	RS 3J	RS 3K	RS 3M	Unit
Maximum Repetitive Peak Reverse Voltage	V_{RRM}	50	100	200	400	600	800	1000	V
Maximum RMS Voltage	V_{RMS}	35	70	140	280	420	560	700	V
Maximum DC Blocking Voltage	V_{DC}	50	100	200	400	600	800	1000	V
Maximum Average Forward Rectified Current	$I_{F(AV)}$	3							A
Peak Forward Surge Current, 8.3 ms Single Half Sine-wave Superimposed on Rated Load (JEDEC method)	I_{FSM}	100							A
Maximum Instantaneous Forward Voltage (Note 1) @ 3 A	V_F	1.3							V
Maximum Reverse Current @ Rated VR $T_A=25\text{ }^\circ\text{C}$ $T_A=125\text{ }^\circ\text{C}$	I_R	10 250							μA
Maximum Reverse Recovery Time (Note 2)	T_{rr}	150			250	500		nS	
Typical Junction Capacitance (Note 3)	C_j	60							pF
Typical Thermal Resistance	$R_{\theta JA}$ $R_{\theta JL}$	50 15							$^\circ\text{C/W}$
Operating Temperature Range	T_J	- 55 to + 150							$^\circ\text{C}$
Storage Temperature Range	T_{STG}	- 55 to + 150							$^\circ\text{C}$

Note 1: Pulse Test with PW=300 usec, 1% Duty Cycle

Note 2: Reverse Recovery Test Conditions: $I_F=0.5\text{A}$, $I_R=1.0\text{A}$, $I_{RR}=0.25\text{A}$

Note 3: Measured at 1 MHz and Applied Reverse Voltage of 4.0V D.C.

RATINGS AND CHARACTERISTIC CURVES (RS3A THRU RS3M)

FIG.1 FORWARD CURRENT DERATING CURVE

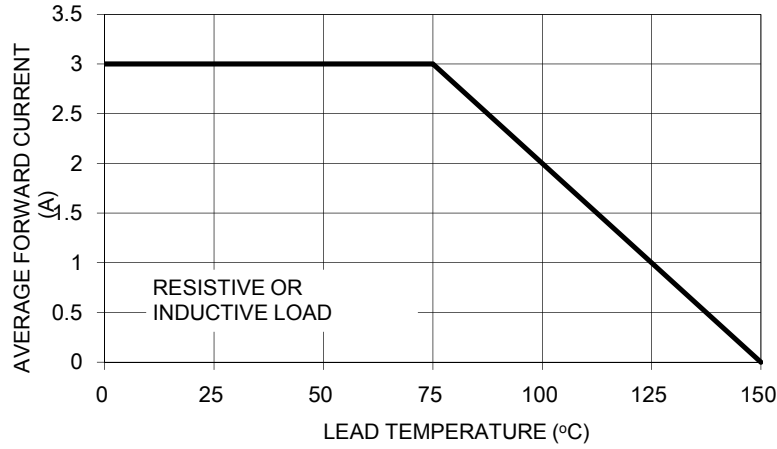

FIG. 2 TYPICAL REVERSE CHARACTERISTICS

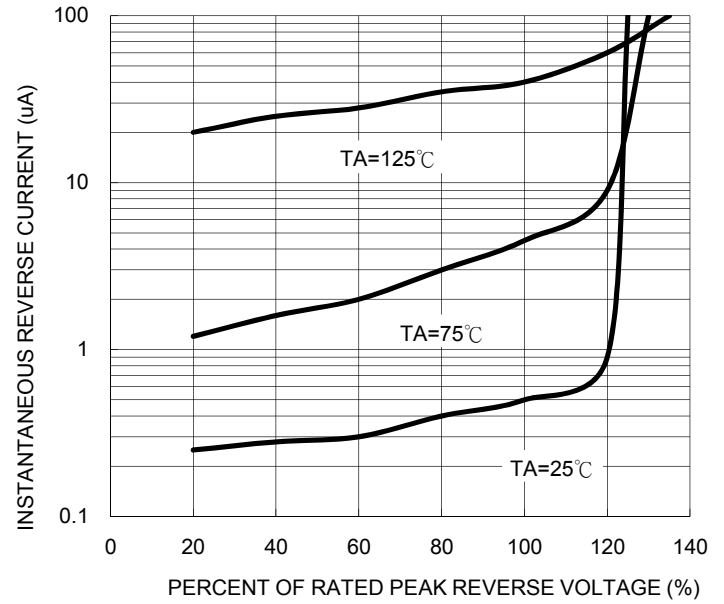

FIG. 3 MAXIMUM NON-REPETITIVE FORWARD SURGE CURRENT

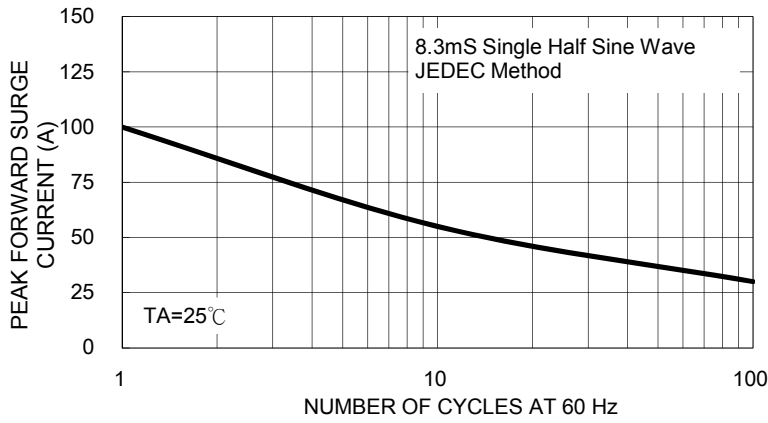

FIG. 5 TYPICAL FORWARD CHARACTERISTICS

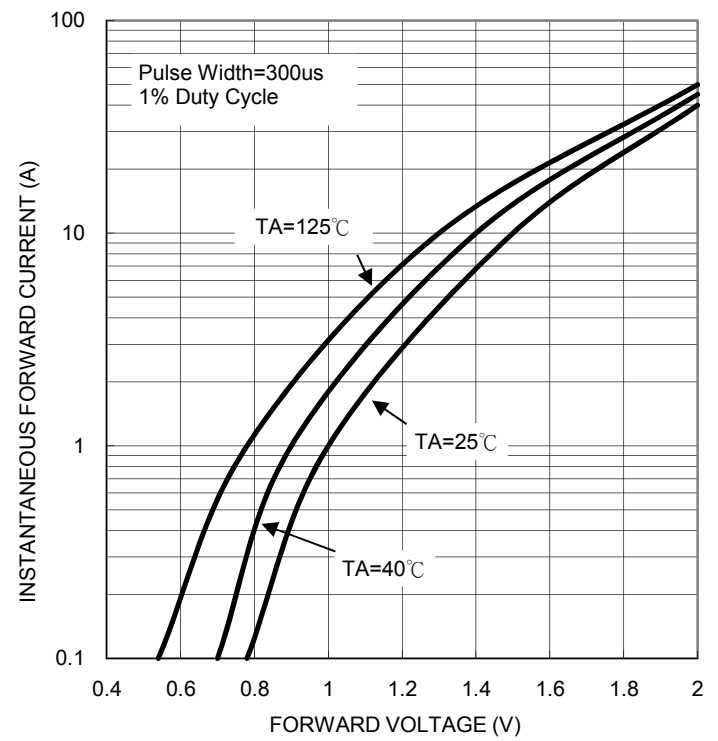

FIG. 4 TYPICAL JUNCTION CAPACITANCE

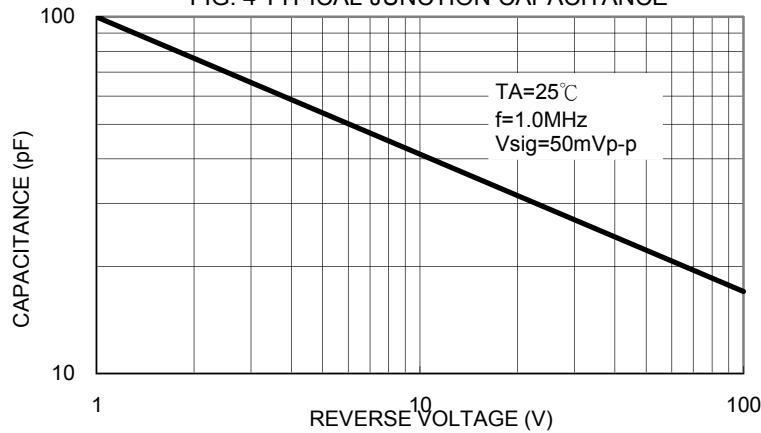
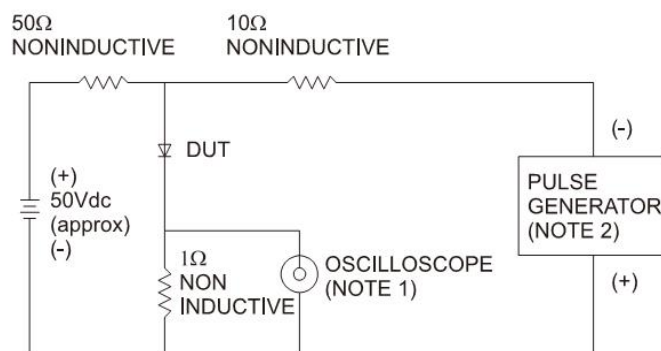
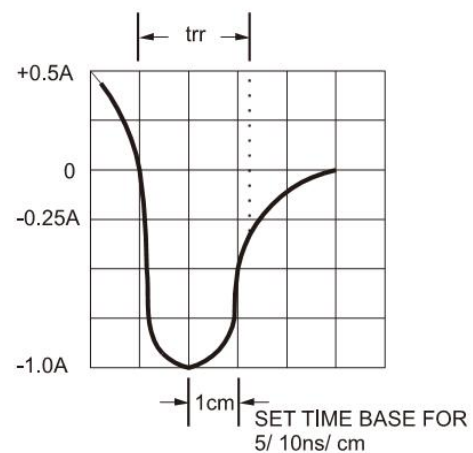

FIG.6- REVERSE RECOVERY TIME CHARACTERISTIC AND TEST CIRCUIT DIAGRAM



NOTES: 1. Rise Time=7ns max. Input Impedance= 1 megohm 22pf
2. Rise Time=10ns max. Source Impedance= 50 ohms



Ordering information

Part No.	Package	Packing	Packing code	Packing code (Green)
RS3x (Note)	SMC	850 / 7" REEL	R7	R7G
	SMC	3K / 13" REEL	R6	R6G
	SMC	3K / 13" Plastic REEL	M6	M6G

Note: "x" is Device Code from "A" thru "M".

Tape & Reel specification

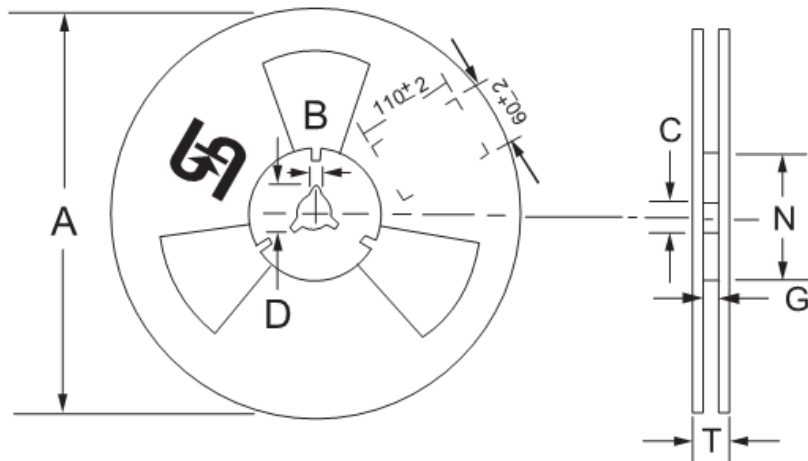
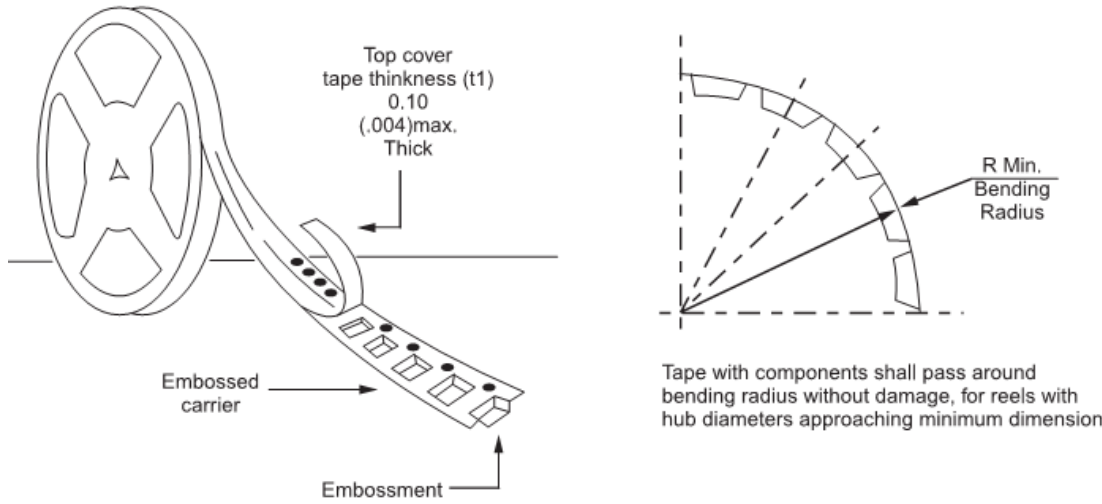

Reel Size	Tape Size	A	B	C	D	N	G	T
		±2.0	±0.4	+0.5;-0.2	min	±1.0	+0.8;-0	max
7"	16mm	178	1.9	13	21	62	16.2	18.6
Reel Size	Tape Size	A	B	C	D	N	G	T
		max	±0.5	±0.5	min	±0.5	+2.0;-0	max
13"	16mm	330	2	13	20.2	75	16.4	22.4

Unit (mm)

Suggested PAD Layout

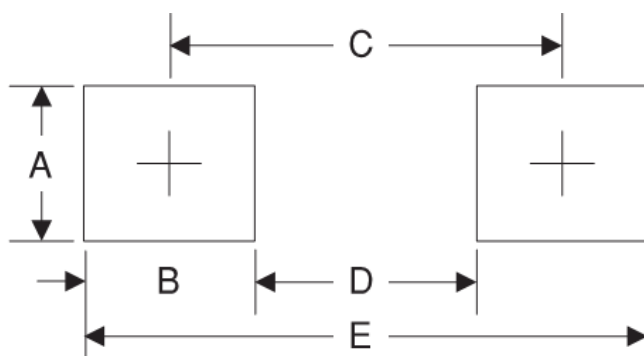

Symbol	Unit(mm)
A	3.3
B	2.5
C	6.8
D	4.4
E	9.3

Dimensions

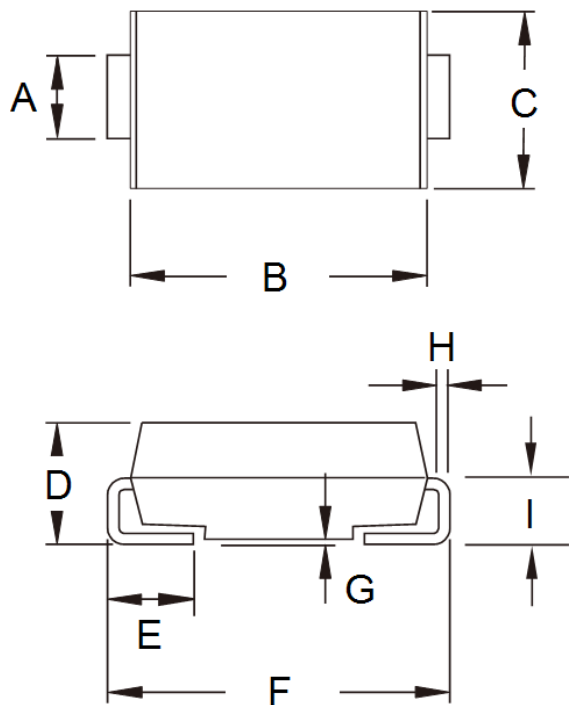

DIM.	Unit(mm)		Unit(inch)	
	Min	Max	Min	Max
A	2.90	3.20	0.114	0.126
B	6.60	7.11	0.260	0.280
C	5.59	6.22	0.220	0.245
D	2.00	2.62	0.079	0.103
E	1.00	1.60	0.039	0.063
F	7.75	8.13	0.305	0.320
G	0.10	0.20	0.004	0.008
H	0.15	0.31	0.006	0.012
I	1.26	1.56	0.050	0.061

Marking Diagram



- P/N = Specific Device Code
- G = Green Compound
- YW = Date Code
- F = Factory Code